

CL1100

Amplified Corded with Big Buttons



Scan the QR code for
support information

vtech[®]
User's manual

Important safety instructions

When using your telephone equipment, basic safety precautions should always be followed to reduce the risk of fire, electric shock and injury, including the following:

1. Read and understand all instructions.
2. Follow all warnings and instructions marked on the product.
3. Do not use liquid or aerosol cleaners. Use a damp cloth for cleaning.
4. **CAUTION:** Do not install the telephone base at a height above 2 metres.
5. Do not use this product near water (for example, near a bath tub, wash bowl, kitchen sink, laundry tub or swimming pool, or in a wet basement or shower).
6. Do not place this product on an unstable table, shelf, stand or other unstable surfaces.
7. Do not expose the telephone to direct sunlight or extreme cold environment. Do not put the telephone close to heating sources such as radiators, cookers, etc.

8. Do not overload wall outlets and extension cords as this can result in the risk of fire or electric shock.
9. Refer servicing to VTech/distributor under the following conditions:
 - If the product does not operate normally by following the operating instructions.
 - If the product has been dropped and the cabinet has been damaged.
 - If the product exhibits a distinct change in performance.
10. Avoid using a telephone (other than a cordless type) during an electrical storm. There may be a remote risk of electric shock from lightning.
11. Do not use the telephone to report a gas leak in the vicinity of the leak.

Disposal of Old Equipment and Batteries (WEEE)

Only for European Union and countries with recycling systems

These symbols (a, b) on the products, packaging, and/or accompanying documents mean that used electrical and electronic products and batteries must not be mixed with general household waste. For proper treatment, recovery and recycling of old products and batteries,

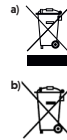

please take them to applicable collection points in accordance with your national legislation.

By disposing of them correctly, you will help to save valuable resources and prevent any potential negative effects on human health and the environment.

For more information about collection and recycling, please contact your local municipality. Penalties may be applicable for incorrect disposal of this waste, in accordance with national legislation.

Product disposal instructions for business users

If you wish to discard electrical and electronic equipment, please contact your dealer or supplier for further information.

Information on Disposal in other countries outside the European Union

These symbols (a, b) are only valid in the European Union. If you wish to discard these items, please contact your local authorities or dealer and ask for the correct method of disposal.

Recycle your device (WEEE directive 2012/19/EU)

The WEEE logo appears on the product to indicate that this product must not be disposed off or dumped with your other household wastes.

You are liable to dispose of all your electronic or electrical waste equipment by relocating over to the specified collection point for recycling of such hazardous waste.

Approval and conformity

This product is intended for use within Europe and the UK. This equipment complies with the essential requirements to EU's Electromagnetic compatibility Directive (2014/30/EU) and the UK's Electromagnetic compatibility Regulations SI 2016/1091 on telecommunication equipment.

VTech Telecommunication Ltd. hereby declares that this telephone CL1100 is in compliance with the essential requirements and other relevant provisions of EU's Electromagnetic compatibility Directive (2014/30/EU) and the UK's Electromagnetic compatibility Regulations SI 2016/1091. The declaration of conformity may be viewed at <https://www.vtechphones.eu>.

The  symbol confirms the conformity of the telephone and the above directive.



Importer: VTech Electronics Europe Plc.
Napier Court, Abingdon Science Park,
Abingdon, Oxfordshire, OX14 3YT.

Manufacturer: VTech
Telecommunications Ltd.
23/F, Tai Ping Industrial Centre, Block 1,
57 Ting Kok Road, Tai Po, Hong Kong.

Customer Service and Product Warranty

IMPORTANT

Please retain this guide with your sales receipt as proof of the date of purchase.

Customer Service

Please call our Customer Services Department at 0330 678 1988 or email to service-ukphone@vtechphones.eu and a service representative will be happy to help you.



PRODUCT WARRANTY

Thank you for choosing this quality product from VTech.

1. The product detailed above is covered by a one year warranty from the date of purchase, against any defects in materials or workmanship.
2. The product may be returned to the place of purchase. Alternatively the product can be returned to VTech Electronics Europe Plc (see address below), with proof of purchase, without proof of purchase no replacement will be provided.
3. VTech Electronics Europe Plc will examine the product and if it is found to be defective due to faulty materials or workmanship, will replace the product at their discretion.
4. If the product covered by this warranty is damaged due to misuse, modification or unauthorized repair, or because of faulty batteries, battery discharge or incorrect electrical connections, then this warranty becomes void.
5. This warranty is personal to the original purchaser and is not transferable.
6. Breakages to the LCD screen are not covered by the warranty.

VTech Electronics Europe Plc, c/o XPO Logistics, Warehouse 350, Cat & Fiddle Lane, West Hallam, DE7 6HE

THIS WARRANTY IS OFFERED AS AN EXTRA BENEFIT AND DOES NOT AFFECT CONSUMERS' STATUTORY RIGHTS.

This warranty is valid for the UK and Ireland only. For products purchased outside the UK and Ireland, please contact your local distributor or place of purchase.

What's in the box

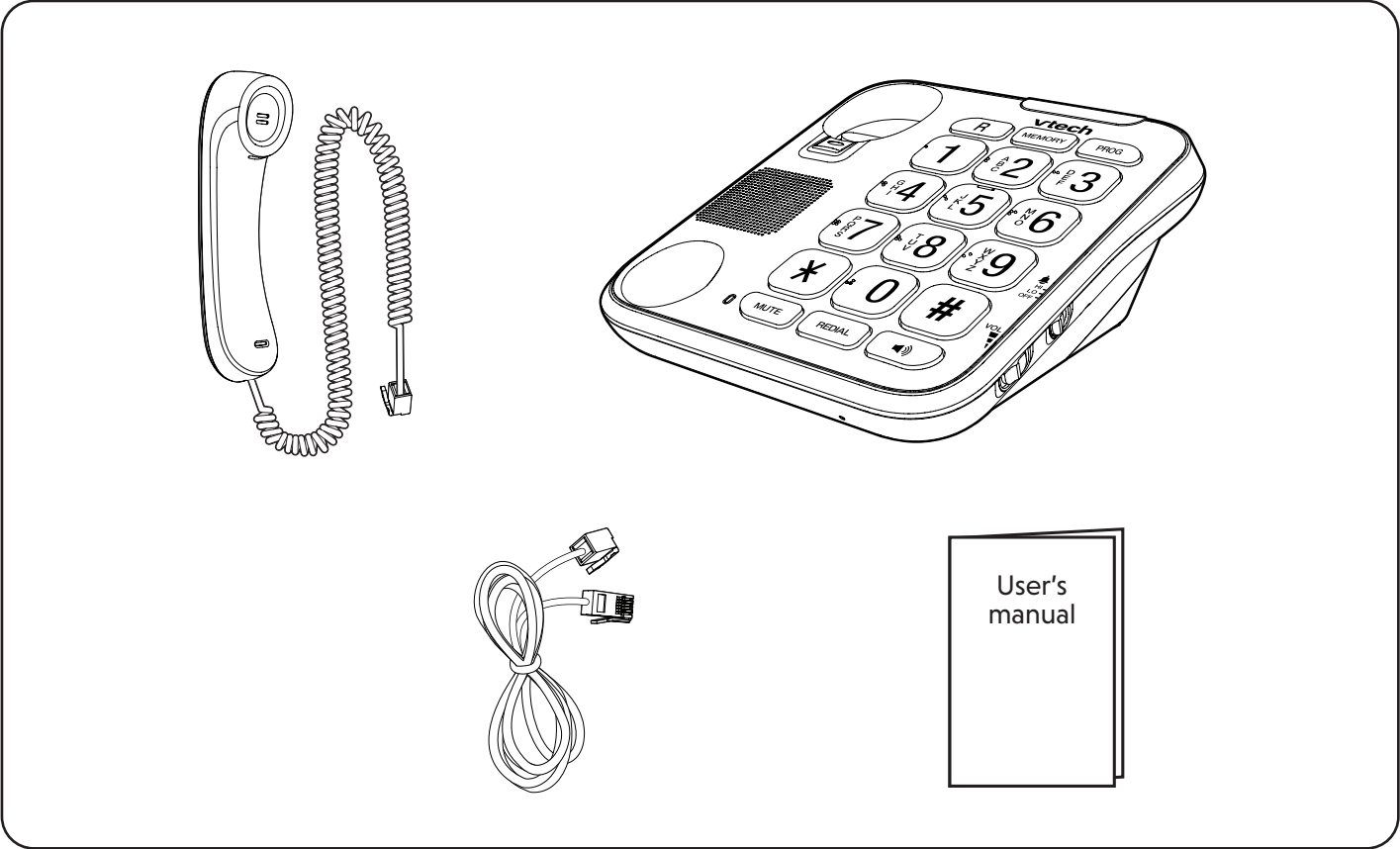

Connect and install

Connect the telephone base

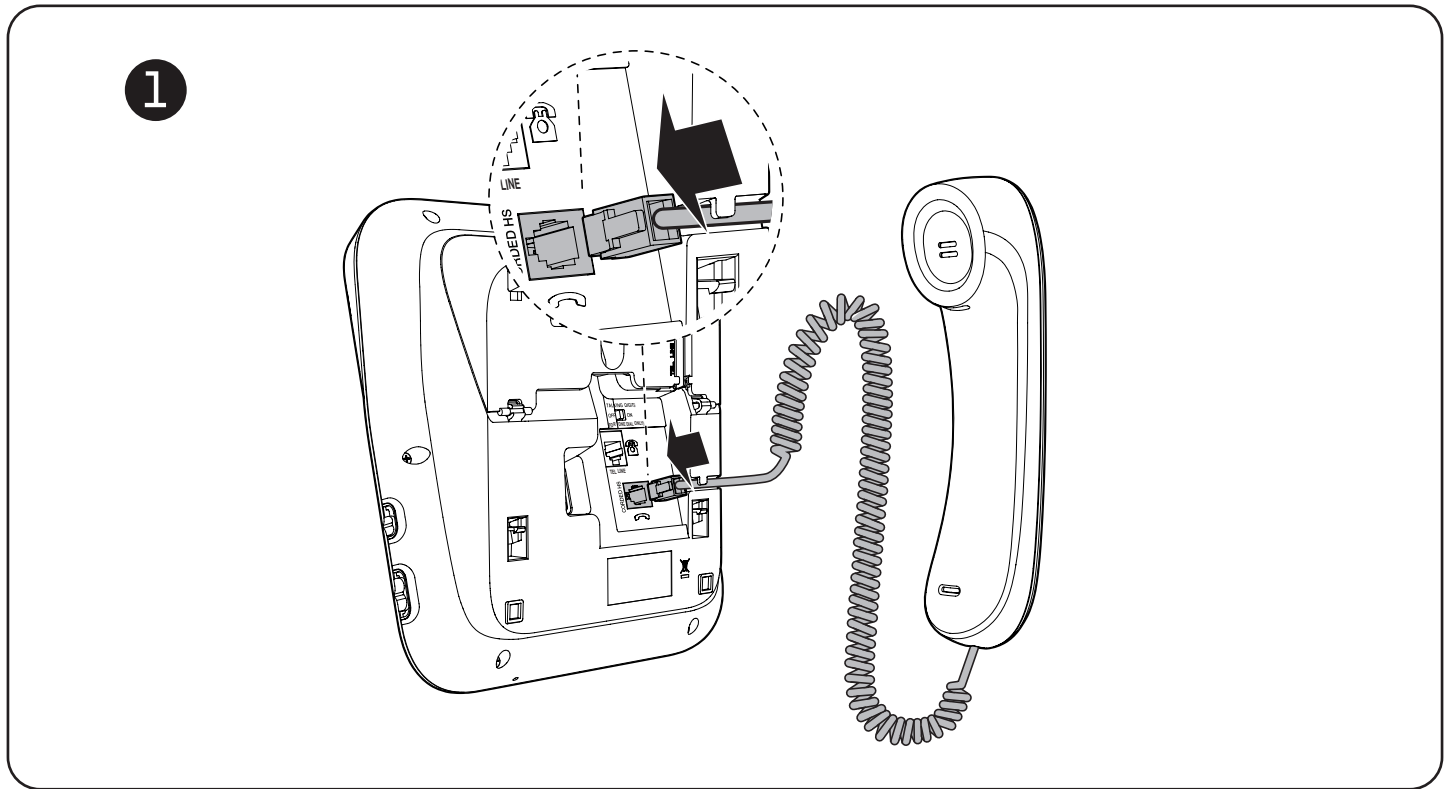

Connect and install

Connect the telephone base

The telephone base is powered from the telephone line. No external power is supplied or required, and there is no battery backup.

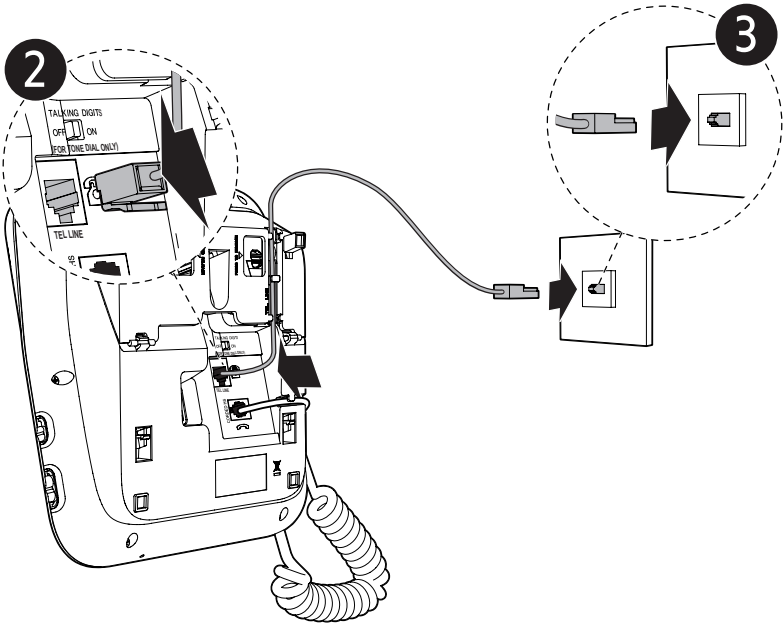

Connect and install

Mount the telephone base (optional)

1

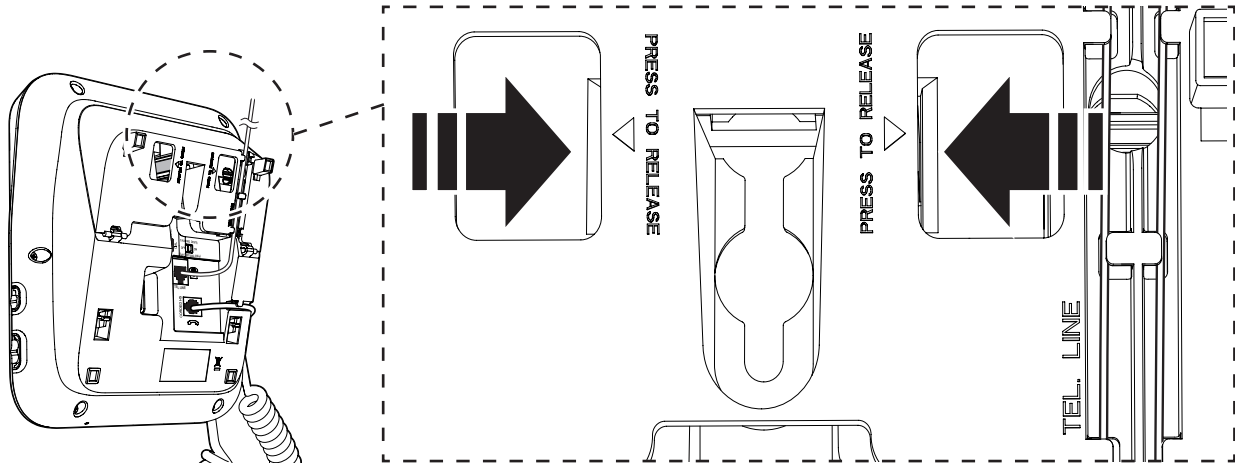

On the **rear side of the telephone base**, press the tabs of the wall-mount bracket to release it from the tabletop orientation.

Connect and install

Mount the telephone base (optional)

2

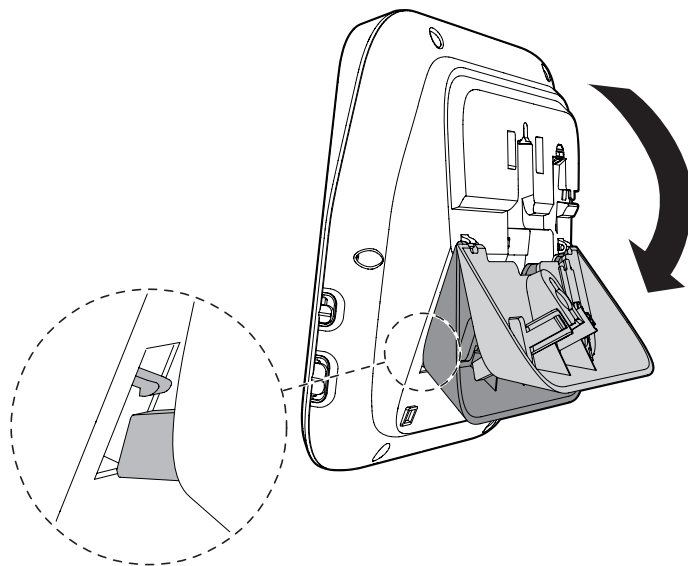

Flip the wall-mount bracket down and push it into the telephone base until it clicks into place.

Connect and install

Mount the telephone base (optional)

3

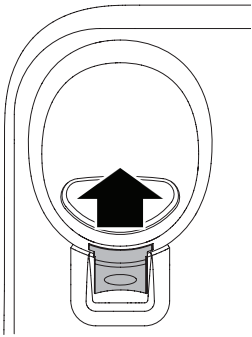

Slide the handset tab upward.

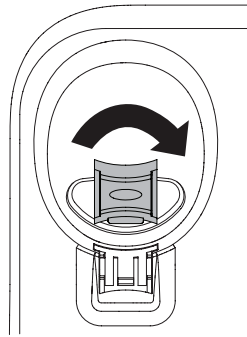

Rotate it upside down.

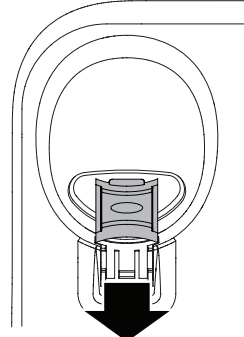

Slide the handset tab back into the slot.

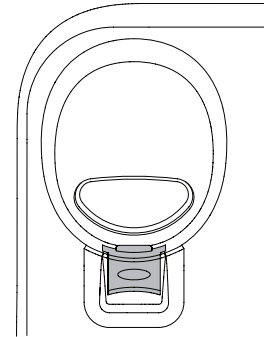

The protruding edge of the handset tab holds the corded handset in place when the telephone is mounted on the wall.

Connect and install

Mount the telephone base (optional)

4

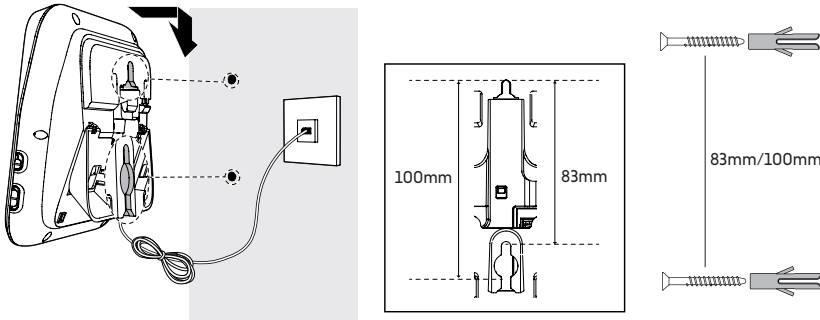

⚠ CAUTION

Do not drill on the wall unless:

- The wall can support the weight of the telephone.
- There are no wirings or plumbings hidden on the wall.
- The telephone line cord can reach the telephone socket from the mounting position.

1. Use a pencil to mark two holes on the wall in parallel.
2. Drill two holes in the wall either 100mm or 83mm apart.
3. Insert the screws (not included) into the holes and tighten the screws until only 1/4 inch of the screws are exposed.
4. Align and mount the telephone to the screws.

Overview

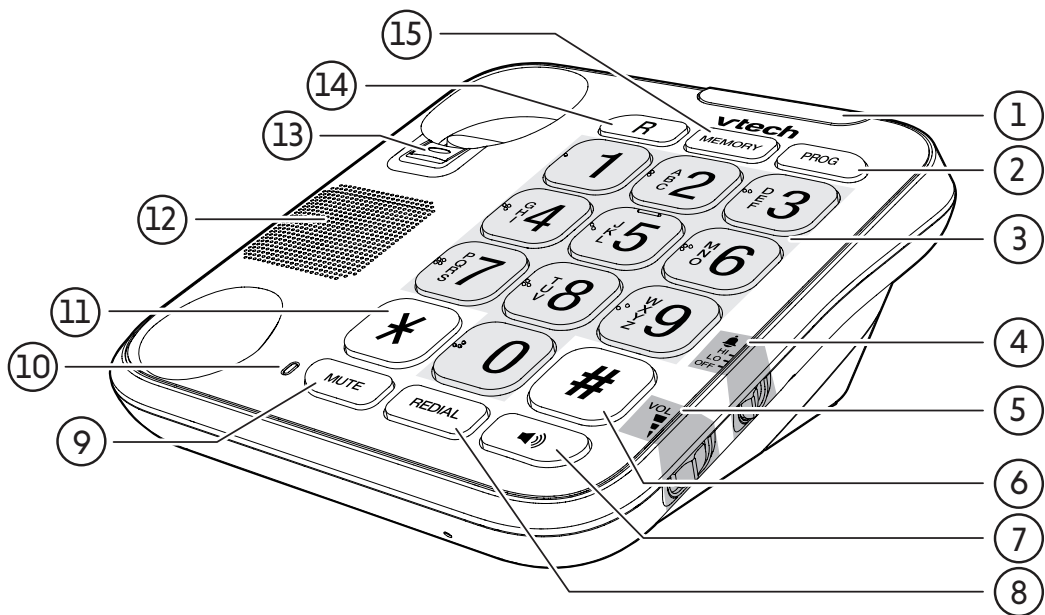





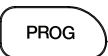

Visual ringer indicator / Line in use LED

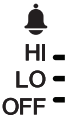

1

- Flashes to indicate an incoming call.
- On when the telephone is in use.

2		<ul style="list-style-type: none"> • Store the number to the selected memory key location .
3	Dial keys (0-9)	<ul style="list-style-type: none"> • Press to dial the numbers. • Press to dial the preset numbers.

Overview

4		<ul style="list-style-type: none"> Adjust the base ringer volume while in idle.
5		<ul style="list-style-type: none"> Adjust the listening volume during a call.
6		<ul style="list-style-type: none"> Hash key.
7		<ul style="list-style-type: none"> Press to make or answer a call using the speakerphone.
8		<ul style="list-style-type: none"> Press to redial the last number. Press to add pause if it is required for dialing.
9		<ul style="list-style-type: none"> Mute the microphone during a call







10	MUTE LED	
	<ul style="list-style-type: none"> The light flashes when MUTE is on. 	
11		<ul style="list-style-type: none"> Switch to tone dialing temporarily during a call.
12	Speaker	
13	Handset tab	<ul style="list-style-type: none"> For optional wall mounting.
14		<ul style="list-style-type: none"> During a call, press to answer an incoming call when you receive a call waiting alert.
15		<ul style="list-style-type: none"> Press to select your desired memory location.

Setup

Speed dial

You can store up to 10 telephone numbers in the memory locations (**0-9**) and to make speed dial calls. We recommend you store contacts that you may need to call them more often.

Add/ Store/ Change/ Remove a speed dial number

1. Press .
 - The **Line in use** LED turns on.
2. Press . Then, press  within 3 seconds.
 - You will hear an administrative tone for entering the programming mode. The **MUTE** LED also turns on.
 - If you do not press  within 3 seconds, the telephone will return to dialing mode.
3. Press a digit (**0-9**) for the memory location, followed by the phone number you want to store.
4. Press  to store the number to the memory location.
 - You will hear a confirmation tone when the number is saved.
 - The newly input number will replace and change the previous one if the memory key had a phone number assigned before.
 - If no number is entered before the  key is pressed again, then the memory location is empty. This will remove a speed dial number if you have assigned one previously.

Setup

Dial a speed dial number while offhook

Press **MEMORY** and then press the desired memory location number (**0-9**).

- The stored number will dial out automatically.

Talking digits

At the base bottom, you can turn on or off the Talking digits feature. This feature announces the number pressed while offhook or during speed dial number storing.

NOTE

- The Talking digits feature is available in Touch tone [**TONE**] mode only.

Language setting for Talking digits

1. Press **Speaker**.
 - The **Line in use** LED turns on.
2. Press **PROG**. Then, press *** (Star)** within 3 seconds.
 - You will hear an administrative tone for entering the programming mode. The **MUTE** LED also turns on.
 - If you do not press *** (Star)** within 3 seconds, the telephone will return to dialing mode.
3. Press **368** (English); or **373** (French); or **338** (German); or **482** (Italian); or **377** (Spanish).
4. Press **# (Hash)** to save the setting. You will hear a confirmation tone.

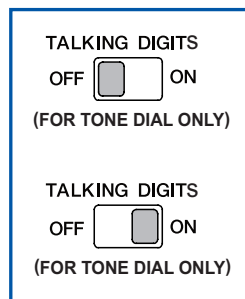

Setup

Dial mode

At the base bottom, you can select the dial mode by sliding the switch - Pulse dialing [**PULSE**] or Touch tone [**TONE**].

- If you need to temporarily switch to Touch tone mode, you can press **X** in offhook mode.

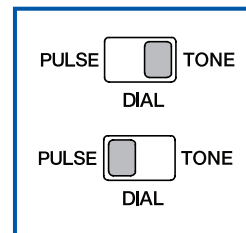

Flash time

You can set the length of flash time. Default setting is short (100ms).

1. Press **MUTE**.
 - The **Line in use** LED turns on.
2. Press **PROG**. Then, press **R** within 3 seconds.
 - You will hear an administrative tone for entering the programming mode. The **MUTE** LED also turns on.
 - If you do not press **R** within 3 seconds, the telephone will return to dialing mode.
3. Press **1** for short (100ms); or **2** for medium (250ms); or **3** for long (600ms).
4. Press **PROG** to save the setting. You will hear a confirmation tone.

Operate

Make a call



Press  or lift the corded handset.

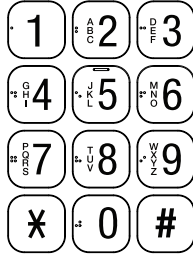

Dial the telephone number.

Answer a call / End a call

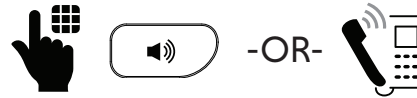

To answer a call, press  or lift the corded handset.

To end a call, press  again or hang up the corded handset.

Speakerphone



While using the corded handset, press  on the telephone base to switch to speakerphone.

Operate

Volume - Speaker / Ringer

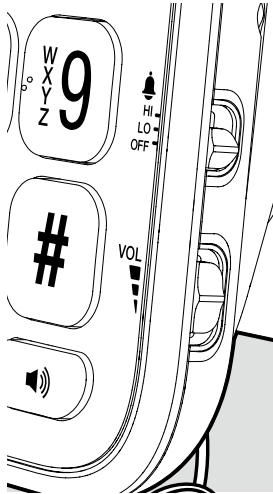

Slide the **VOL** control to adjust the corded handset or the speaker volume level when on a call.



Slide the **Ringer** control to adjust the ringer volume level.

- You cannot change the ringer tone.

⚠ CAUTION

- For hearing protection, loud ringer and sound may damage your hearing. Adjust the volume to lower the ringer and sound if you find it too loud.





Operate

Call waiting

When you subscribe to call waiting service from your telephone service provider, you hear an alert tone if there is an incoming call while you are already on a call.



1. Press  on the telephone base to put the current call on hold and take the new call.
2. Press  at any time to switch back and forth between calls.

Redial

The last dialed telephone number is stored in the telephone base.

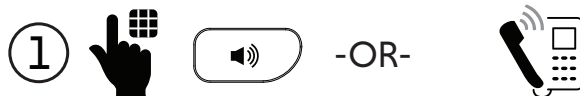

To redial the last number, press the speakerphone or lift the corded handset.



General product care

To keep your telephone working well and looking good, follow these guidelines:

- Avoid putting it near heating appliances and devices that generate electrical noise (for example, motors or fluorescent lamps).
- Do not expose it to direct sunlight or moisture.
- Avoid dropping the telephone or treating it roughly.
- Clean with a soft cloth.
- Never use a strong cleaning agent or abrasive powder because this can damage the finish.
- Retain the original packaging in case you need to ship it at a later date.



Specifications are subject to change without notice.

©2023 VTech Telecommunications Ltd.

All rights reserved. 12/23. CL1100_UM_UK_V2

