

VM819 Video Baby Monitor



vtech® Quick start guide



© 2023 Vtech Communications, Inc. All rights reserved.
07/23 VM819-X-05G, UK, VZ
Specifications are subject to change without notice.
The Heart Beat sound file was created by Zanebebe, and is used under the Creative Commons license.
The Crickets At Night sound file was created by Mike Koenig, and is used under the Creative Commons license.
The Stream Noise sound file was created by Carsten Ford, and is used under the Creative Commons license.
Credits: The Background Noise sound file was created by Carsten Ford, and is used under the Creative Commons license.

Power requirements	Parent unit: 3.6V 2600mAh, 9.36Wh Li-ion battery
Parent unit power adaptor: Output: 5V DC @ 400mA	
Baby unit power adaptor: Output: 6V DC @ 400mA	
Nominal effective range	Actual operating range may vary according to environmental conditions at the time of use.
LCD	2.8" Colour LCD (QVGA 320x240 pixels)
Channels	32
Transmit frequency	Baby unit: 2405 - 2475 MHz Parent unit: 2405 - 2475 MHz
Frequency control	Crystal controlled PLL synthesizer

TECHNICAL SPECIFICATIONS

IMPORTANT SAFETY INSTRUCTIONS

- The applied nameplate is located at the bottom of the baby unit's base.
- When using your equipment, basic safety precautions should always be followed to reduce the risk of fire, electric shock and injury, including the following:
- Follow all warnings and instructions marked on the product.
 - Adult setup is required.
 - CAUTION:** Do not install the baby unit at a height above 2 metres.
 - This product is intended as an aid. It is not a substitute for responsible and proper adult supervision and should not be used as such.
 - This product is not intended for use as a medical monitor.
 - Do not use this product near water, for example, near to a bath, sink, swimming pool or shower.
 - CAUTION:** Use only the battery provided. There may be a risk of explosion if a wrong type of battery is used for the parent unit. The battery cannot be subjected to high or low extreme temperature and low air pressure at high altitude during use, storage or transportation. Disposal of battery in fire or a hot oven, mechanically crushing or cutting the battery can result in an explosion. Leaving the battery in an extremely high temperature surrounding environment can result in an explosion or the leakage of flammable liquid or gas. Battery subjected to extremely low air pressure may result in an explosion or the leakage of flammable liquid or gas. Dispose of used batteries according to the instructions.
 - Use only the power adaptors included with this product. Incorrect power adaptor polarity or voltage can seriously damage the product.
 - Power adaptor information: Parent unit output: 5V DC 1A Vtech Telecommunications Ltd. Model: VT05EUK05100
 - Baby unit output: 6V DC 400mA. Vtech Telecommunications Ltd. Model: VT05EUK06040
 - Rechargeable battery information: Zhuhai Great Power Energy Ltd. Li-ion battery, 3.6V 2600mAh, 9.36Wh; Model: ICR18650-2.6Ah-3.6V-151P
 - The power adaptors are intended to be correctly oriented in a vertical or floor mount position. The prongs are not designed to hold the plug in place if it is plugged into a ceiling, under-the-table or cabinet outlet.
 - For pluggable equipment, the socket-outlet should be installed near the equipment and should be easily accessible.
 - Unplug this product from the wall outlet before cleaning. Do not use liquid or aerosol cleaners. Use a damp cloth for cleaning.
 - Do not modify the power adaptors or replace with other adaptors, as this causes a hazardous situation.
 - Do not allow anything to rest on the power cords.
 - Do not install this product where the cords may be walked on or crimped.
 - This product should be operated only from the type of power source indicated on the marking label. If you are not sure of the type of power supply in your home, consult your dealer or electricity supply provider.
 - Do not overload wall outlets or use an extension cord.
 - Do not place this product on an unstable table, shelf, stand or other unstable surfaces.
- This product should not be placed in any area where proper ventilation is not provided. Slots and openings in the back or bottom of this product are provided for ventilation. To protect them from overheating, these openings must not be blocked by placing the product on a soft surface such as a bed, sofa or rug. This product should never be placed near or over a radiator or heat source.
- Never push objects of any kind into this product through the slots because they may touch dangerous voltage points or create a short circuit. Never spill liquid of any kind on the product.
 - To reduce the risk of electric shock, do not disassemble this product, but take it to an authorised service facility. Disassembling or removing parts of the product other than via the battery door may expose you to dangerous voltages or other risks. Incorrect reassembly can cause electric shock when the product is subsequently used.
 - You should test the sound reception every time you turn on the units or move one of the components.
 - Periodically examine all components for damage.
 - There is a very low risk of privacy loss when using certain electronic devices, such as baby monitors, cordless telephones, etc. **To protect your privacy, make sure the product has never been used before purchase, reset the baby monitor periodically by powering off and then powering on the units, and power off the baby monitor if you are not intending to use it for some time.**
 - The small parts of this monitor can be swallowed by babies or small children. Keep these parts out of reach of children.
 - Children should be supervised to ensure that they do not play with the product.
 - The product is not intended for use by persons (including children) with reduced physical, sensory or mental capabilities, or lack of experience and knowledge, unless they have been given supervision or instruction concerning use of the appliance by a person responsible for their safety.
- SAVE THESE INSTRUCTIONS**
- Cautions**
- Use and store the product at a temperature between 0°C and 40°C.
 - Do not expose the product to extreme cold, heat or direct sunlight. Do not put the product close to a heating source.
 - Batteries should not be exposed to excessive heat such as bright sunshine or fire.
 - Mishandling batteries can cause burn, fire or explosion hazards.
 - Warning—Strangulation Hazard—** Children have STRANGLED in cords. Keep this cord out of the reach of children (more than 0.9m away). Do not remove warning label on the adaptor cord.
 - Never place the baby unit(s) inside the baby's cot or playpen. Never cover the baby unit(s) or parent unit with anything such as a towel or a blanket.
 - Other electronic products may cause interference with your baby monitor. Try installing your baby monitor as far away from these electronic devices as possible: wireless routers, radios, cellular telephones, intercoms, room monitors, televisions, personal computers, kitchen appliances and cordless telephones.

WHAT'S IN THE BOX

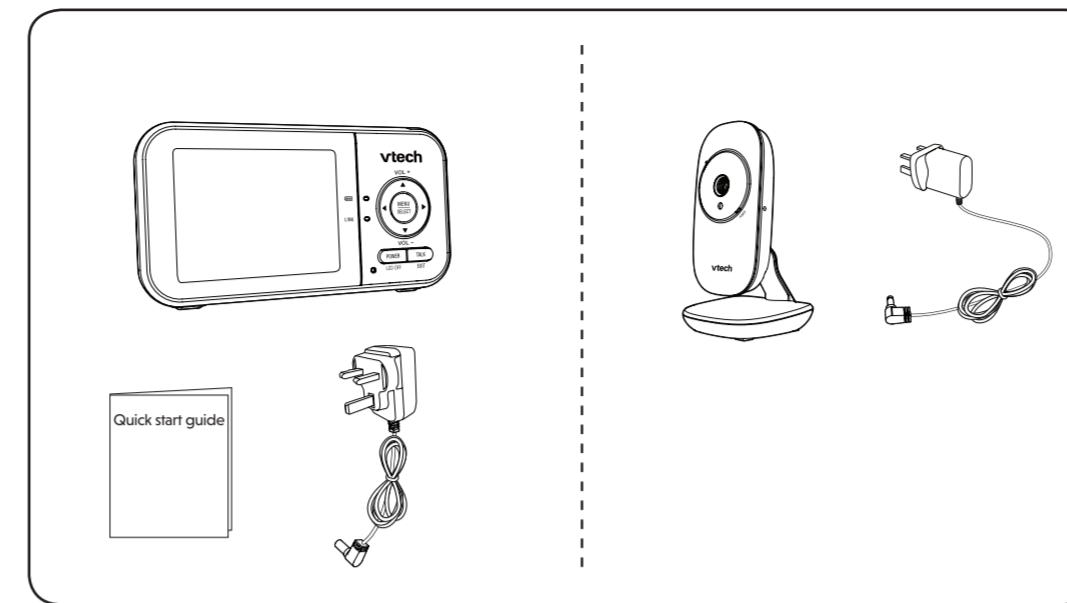

1 CONNECT THE BABY MONITOR

The parent unit turns on automatically after connecting the power adaptor to the power socket and the battery LED light illuminates for a few seconds, then turns off.

NOTES

- The rechargeable battery in the parent unit is built-in.
- Use only the power adaptors supplied with this product.
- Make sure the baby monitor is not connected to an electronically-controlled electric outlet.
- Connect the power adaptors in a vertical or floor mount position only. The adaptor prongs are not designed to hold the weight of a baby monitor, so do not connect them to any ceiling, under-the-table, or cabinet outlets. Otherwise, the adaptors may not properly connect to the outlets.
- Make sure the parent unit, the baby unit and the power adaptor cords are out of reach of children.

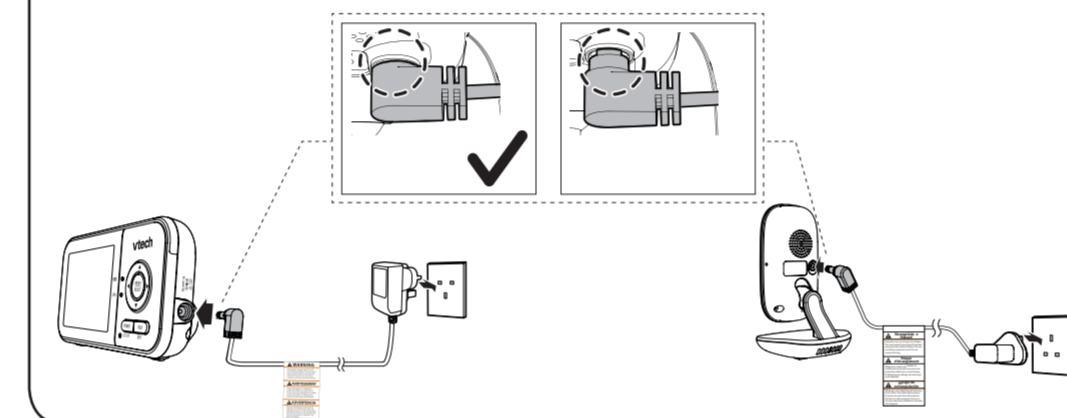

1 CONNECT THE BABY MONITOR (CONT'D)

Charge the parent unit battery
When you have connected and turned on the parent unit, the battery will be charged automatically.

NOTES

- Before using the baby monitor for the first time, charge the parent unit battery for 12 hours. When the parent unit battery is fully charged, the battery icon segments are solid.
- It takes longer to charge the battery when the parent unit is turned on. To shorten the charging time, turn the parent unit off while charging.
- The standby time varies depending on the sensitivity level you set, your actual use and the age of the battery.

The battery icon indicates the battery status (see the following table).

BATTERY INDICATORS	BATTERY STATUS	ACTION
The screen displays . The light flashes.	The battery has very little charge and may be used for only a short time.	Charge without interruption (about 30 minutes).
The battery icon segments are solid .	The battery is fully charged.	To keep the battery charged, connect it to AC power when in use.

2 POWER ON OR OFF THE BABY MONITOR

- Slide the **ON/OFF** switch to power on or off your baby unit.
- Press and hold **POWER** to power on or off your parent unit.

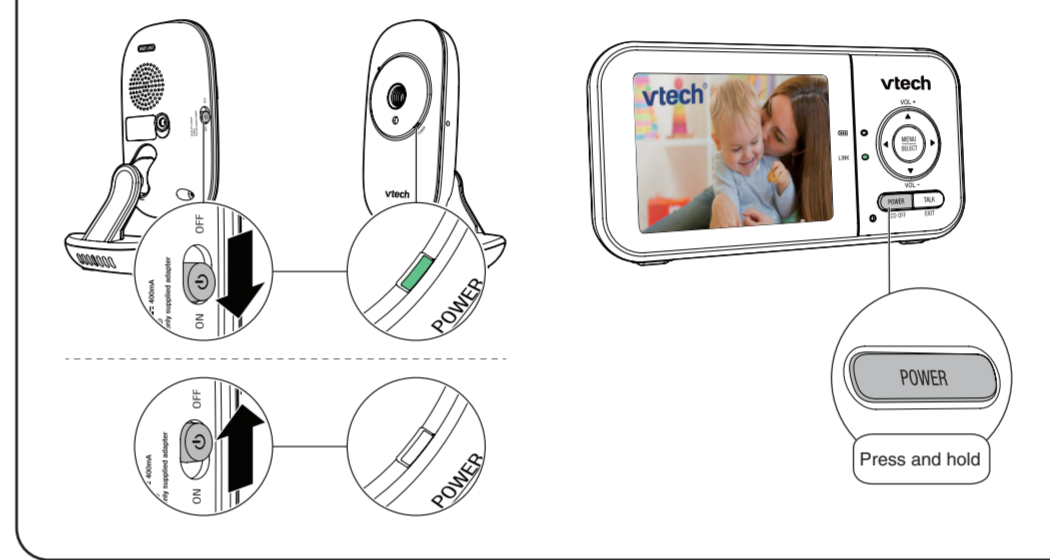

3 POSITIONING THE BABY MONITOR

CAUTION

- Keep the baby unit out of the reach of your baby. Never place or mount the baby unit inside the baby's crib or playpen.

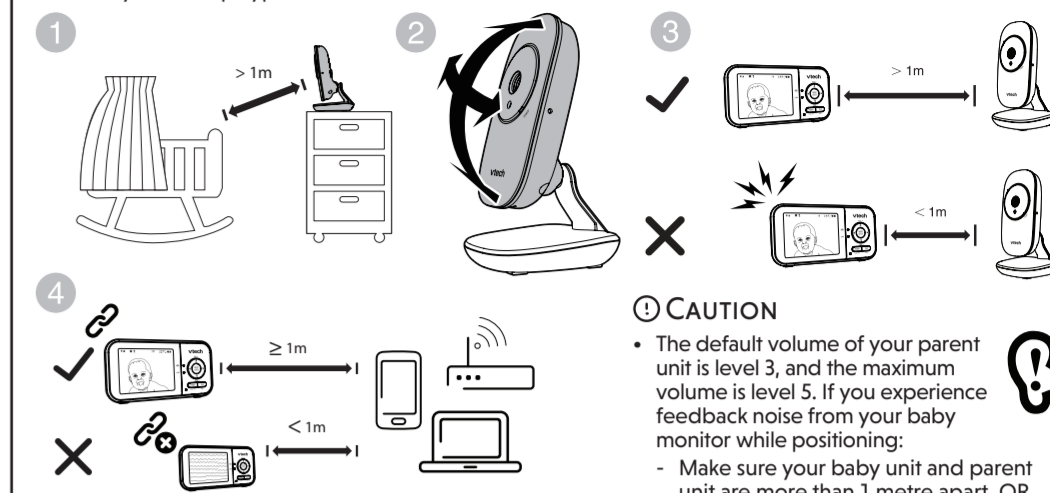

NOTE

- To avoid interference from other electronic devices, place your baby monitor at least 1 metre away from devices such as wireless routers, microwaves, mobile phones and computers.

CAUTION

- For optimal range, please avoid covering the area indicated with hands during use.

4 STATUS CHECK

Once you power on both your baby unit and parent unit, your parent unit displays images from the baby unit, and the **LINK** LED light turns on.

The baby unit **POWER** LED light turns on.

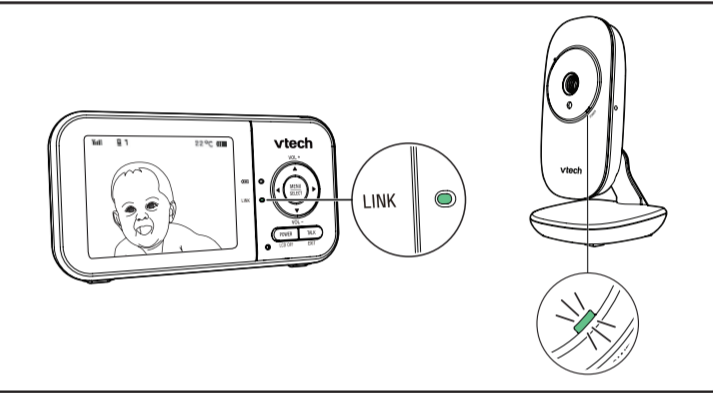

BASIC OPERATION - PARENT UNIT

Use the menu

Press **MENU** to enter the menu, or save a setting. You can use the parent unit for advanced settings or operations, such as to play or stop the baby unit lullaby, or to adjust the baby unit's sound sensitivity.

While in the menu:

- Press **←** or **→** to scroll among the menu options.
- Press **▲** or **▼** to select an item.
- Press **SELECT** to confirm your selection.
- Press **TALK/EXIT** to exit the menu and return to live view.

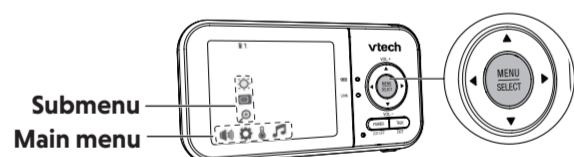

Talk to your baby unit

Press and hold **TALK** and speak to your parent unit. Your voice is transmitted to the baby unit. When finished talking, release the **TALK** key to hear your baby again.

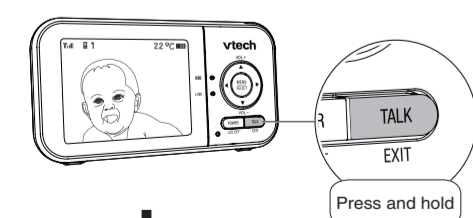

Turn off the screen

Press **POWER/LCD OFF** to switch off the screen. You can still hear sound from the baby unit.

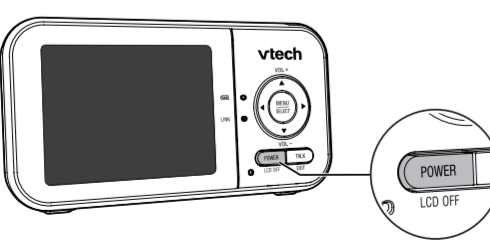

TIP

- Press any keys on the parent unit to turn on the screen again.

Adjust parent unit speaker volume

- Press **▲ VOL+** / **▼ VOL-** to adjust your parent unit speaker volume.

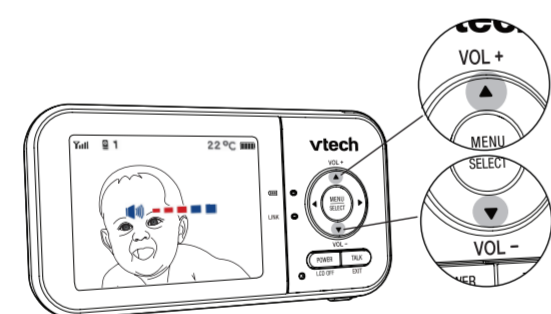

Zoom

- Press **MENU** when in idle mode.
- Choose .
- Press **▲** or **▼** to choose **2X** (Zoom in) or **1X** (Zoom out), then press **SELECT** to confirm your selection.

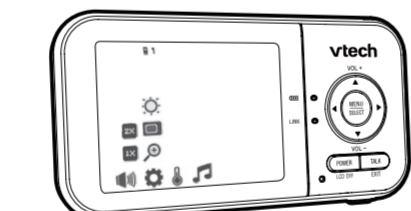

OVERVIEW - PARENT UNIT

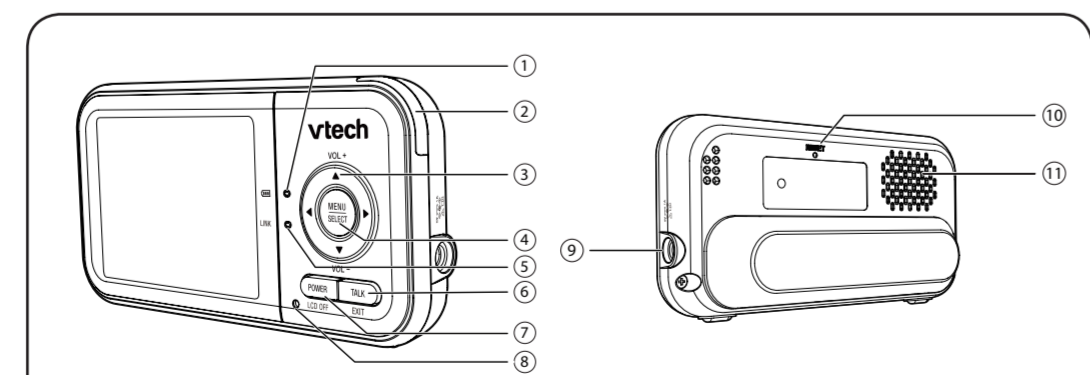

- | | | |
|--|---|---------------------------------|
| 1 Battery LED light | 5 LINK LED light | 7 POWER/LCD OFF |
| 2 3-level sound indicator light | • On when the parent unit is linked to the baby unit. | 8 Microphone |
| 3 Arrow keys | • Flashes when the link to the baby unit is lost. | 9 Power jack |
| • ▲ VOL+ / ▼ VOL- | | 10 RESET |
| 4 MENU/SELECT | 6 TALK/EXIT | • Force reboot the parent unit. |
| | • Press and hold to talk to the baby unit. | 11 Speaker |
| | • While in a submenu, press to exit. | |

OVERVIEW - BABY UNIT

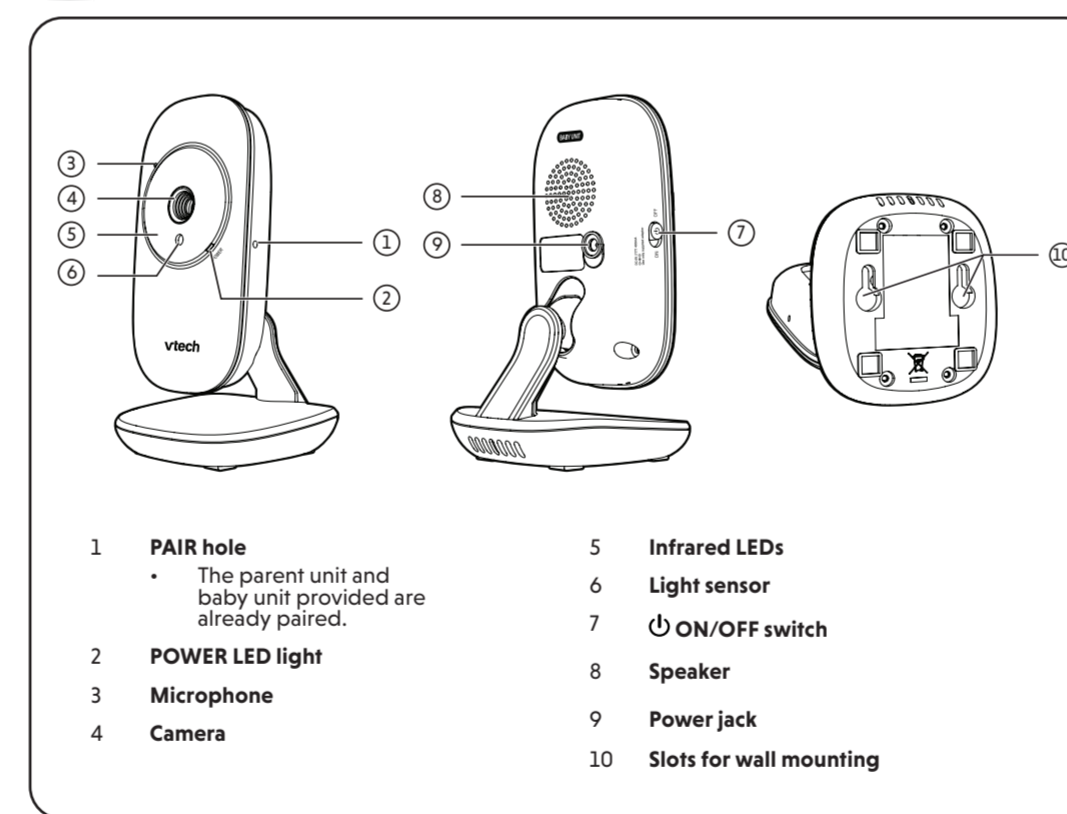

- | | |
|--|-----------------------------------|
| 1 PAIR hole | 5 Infrared LEDs |
| • The parent unit and baby unit provided are already paired. | 6 Light sensor |
| 2 POWER LED light | 7 ON/OFF switch |
| 3 Microphone | 8 Speaker |
| 4 Camera | 9 Power jack |
| | 10 Slots for wall mounting |

PARENT UNIT ICONS

Status icons

- Signal strength**
 - or displays when strong signal strength is detected between the baby unit and the parent unit.
 - or displays when moderate or low signal strength is detected between the baby unit and the parent unit.
- Current view status**
 - Displays the number of the baby unit being viewed.
- Zoom**
 - Displays when the current image on the parent unit has zoomed in.
- Night vision**
 - Displays when the baby unit being viewed has activated the night vision feature.
- Talkback**
 - Displays when talking back to the baby units from parent unit.
- Lullaby**
 - Displays when a lullaby is playing.
- Mute alert**
 - Displays when the parent unit speaker volume is set to zero.
 - Displays whenever the parent unit is talking to the baby unit.
- Real-time temperature**
 - Displays the real-time temperature detected by the baby unit in Fahrenheit (°F) or Celsius (°C) (e.g. 57°F or 14°C).
- Battery status**
 - animates when the battery is charging.
 - displays solid when the battery is fully charged.
 - displays when the battery is low and needs charging.

Main menu icons

- | | | | |
|---|--|--|--|
| Main menu | Sub-menu | Main menu | Sub-menu |
| Volume | <ul style="list-style-type: none"> Parent unit speaker volume Adjust the parent unit speaker volume. | Settings | <ul style="list-style-type: none"> Brightness Adjust the parent unit LCD screen brightness level. |
| Settings | <ul style="list-style-type: none"> Screen off timer The parent unit screen will turn off after the selected time to save energy. You can still hear your baby while the screen is turned off. VOX (Voice Activated Alert) Sensitivity When VOX is selected, the parent unit screen will automatically turn on when detected sounds exceed a set level. You can adjust the baby unit microphone sensitivity level so that the higher the sensitivity level, the more sensitive the baby unit is in detecting sounds for transmitting to the parent unit. For details, see the Sound sensitivity and sound activation section. The parent unit will then turn off again after 50 seconds if the sound detected is lower than the set level. | <ul style="list-style-type: none"> Zoom Zoom in and out of the video displayed from the baby unit. Temperature Turn on/off temperature alert tone. Set the parent unit to beep whenever the room temperature detected by the baby unit falls outside of the set temperature range. Set the minimum/maximum temperature. Set temperature display in Fahrenheit (°F) or Celsius (°C). | |
| NOTE | | | |
| When the parent unit screen is off, if alerts are received, for example, no signal received between the parent unit and baby unit, or a low battery, the parent unit screen will turn on. | | | |

☰ PARENT UNIT ICONS (CONT'D)

Main menu icons

Main menu

Lullaby



Lullaby volume

- Adjust the baby unit speaker volume when playing the lullaby.



STOP 1 2 3 4

- Select one of the four melodies to play, or stop a lullaby.

Warning icons and messages

Battery low at Parent Unit



The battery is empty and needs to be recharged.

Operation is in progress.



Temperature too high



The temperature detected by the baby unit is higher than the maximum temperature alert setting.

Temperature too low



The temperature detected by the baby unit is lower than the minimum temperature alert setting.

No Link to Camera



The parent unit is searching for baby unit or the link between the baby unit and the parent unit has been lost, for example, due to out of range.

The parent unit is connected to AC power.



Parent Unit Indication Lights

LINK

- On when the parent unit is linked to the baby unit.
- Flashes when the link to the baby unit is lost.

LINK

- On when the parent unit is connected to AC power, or the battery is charging.
- Flashes when the parent unit battery is low and needs charging.
- Off when the parent unit is disconnected from AC power.

📶 SOUND SENSITIVITY AND SOUND ACTIVATION

Adjust the sound sensitivity of the baby unit

The parent unit screen will turn on only when the detected sounds exceed a set level.

Use the parent unit to adjust the microphone sensitivity of your baby unit. The higher the sensitivity level, the more sensitive the baby unit is in detecting sounds that transmit to the parent unit. The VOX sensitivity level is preset to the highest level.

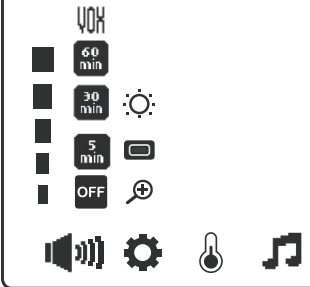

VOX SENSITIVITY LEVEL	Highest	High	Medium	Low	Lowest
DESCRIPTION	The parent unit screen turns on for quiet sounds, (including background noises) from your baby's room.	The parent unit screen turns on for soft babbling and louder sounds from your baby. It remains off when your baby sleeps soundly.	The parent unit screen turns on for loud babbling and louder sounds from your baby. It remains off when your baby makes soft sounds.	The parent unit screen turns on for crying and louder sounds from your baby. It remains off when your baby makes soft sounds.	The parent unit screen turns on for loud crying or screeching sounds from your baby. It remains off when your baby makes soft sounds.

When **VOX** is selected, the parent unit screen stays off to save power when the baby unit detects sounds that are lower than the set sensitivity level. Once the baby unit detects sounds that are louder than the set sensitivity level, the parent unit screen turns on automatically. It will then turn off again after 50 seconds if the sounds detected are lower than the set sensitivity level.

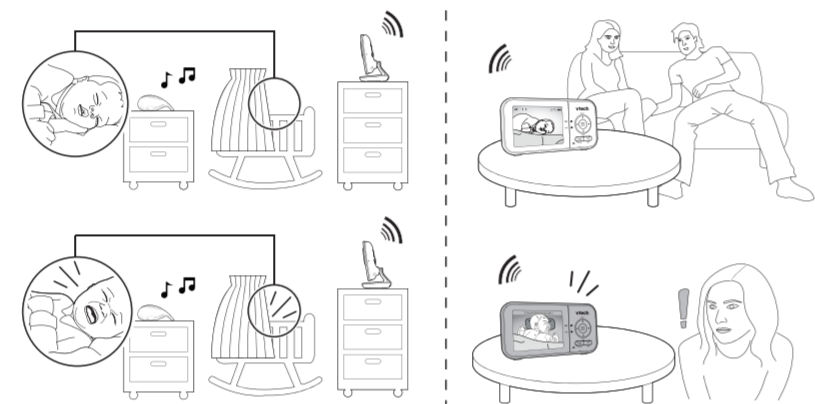

📺 DIM MODE

Dim mode helps you save parent unit power. Your parent unit display will automatically dim after 10 minutes of inactivity, when no keys are pressed or alerts are received from the baby unit.

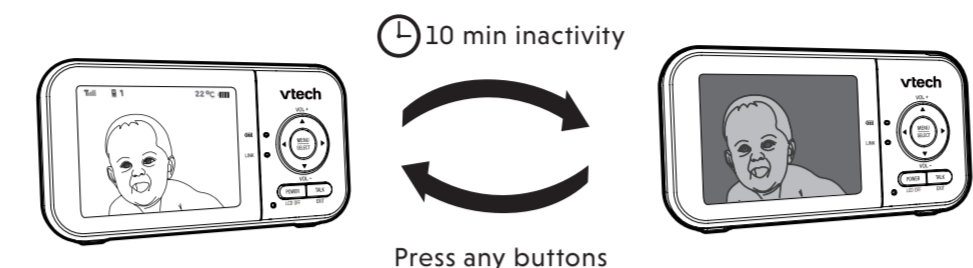

NOTE

- While the screen is dimmed, any keypress or alert message will trigger the screen to return to the preset brightness level. After 10 minutes of inactivity, it will resume back to dim mode.

🌙 NIGHT VISION

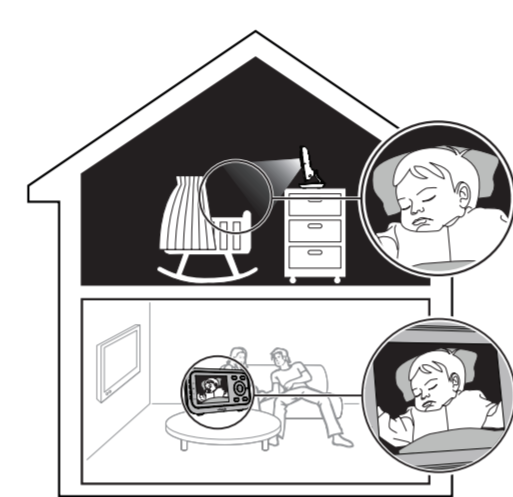

The baby unit has infrared LEDs that allow you to see your baby clearly at night or in a dark room. When the baby unit detects low light levels, the infrared LEDs are switched on automatically. The images from the baby unit are in black and white, and  appears on the screen.

NOTE

- It is normal to see a short white glare on your parent unit screen when the baby unit adapts to the dark environment.
- When the infrared LEDs are on, the images are in black and white. This is normal.

TIP

- Depending on the surroundings and other interfering factors, for example, lighting, objects, colours and backgrounds, the image quality may vary. Adjust the baby unit angle or place the baby unit at a higher location to prevent glare and a blurred display.

🔧 MOUNT THE BABY UNIT ON DRY WALL (OPTIONAL)

Items to purchase

You will need to purchase the following items separately to mount your baby unit:

- 2 screws
- 2 wall plugs

NOTE

- The types of screws and wall plugs you need depend on the composition of the wall.

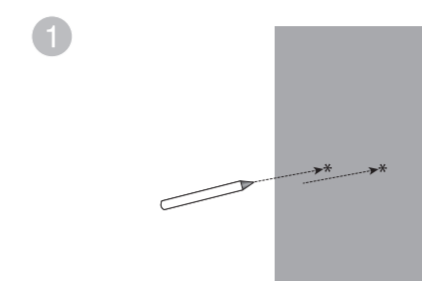

NOTE

- Check for reception strength and camera angle before drilling the holes.

Use a pencil to mark two holes in parallel. Make sure they are the same distance apart as the wall mount holes on the baby unit.

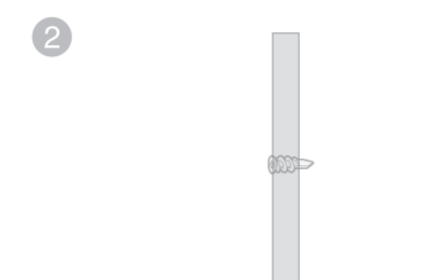

Drill two holes in the wall (5.5mm drill bit). If you drill the holes into a stud, go to step 3.

-OR-

If you drill the holes into an object other than a stud, insert the wall plugs into the holes. Tap gently on the ends with a hammer until the wall plugs are flush with the wall.

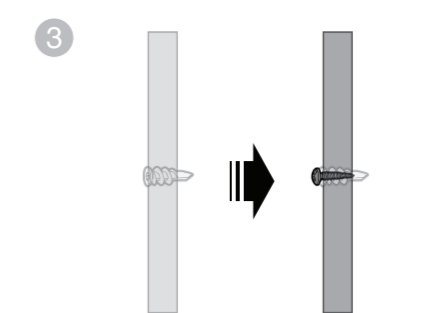

Insert the screws into the holes and tighten the screws until only 6.5mm of the screws are exposed.

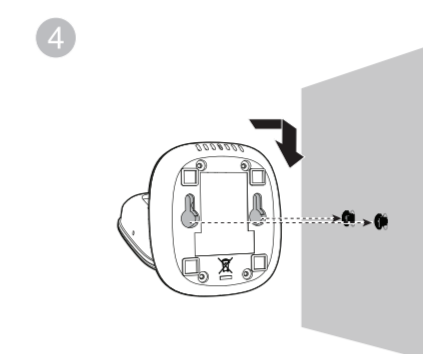

Align the wall mount holes on the baby unit with the screws on the wall. Slide the baby unit down until it locks into place.

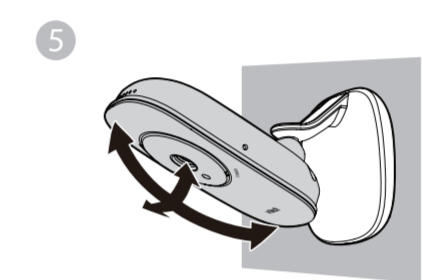

Adjust the camera angle.

🗋️ FREQUENTLY ASKED QUESTIONS

Below are the questions most frequently asked about the baby monitor.

Why does the baby monitor not respond normally?	Try the following (in the order listed) for common cure: 1. Disconnect the power to the baby unit and the parent unit. 2. Wait a few seconds before connecting power back to the baby unit and the parent unit. 3. Turn on the baby unit and the parent unit. 4. Wait for the parent unit to synchronise with the baby unit. Allow up to one minute for this to take place.
Why doesn't the baby unit and parent unit power-on light illuminate when the units are switched on?	Perhaps the parent unit is not connected to the power. Insert the adaptor plug into the parent unit and insert the adaptor in a wall socket. Then, press and hold POWER to switch on the parent unit to establish connection with the baby unit. Perhaps the baby unit is not connected to the power. Insert the adaptor plug into the baby unit and insert the adaptor in a wall socket. Then, slide the ON/OFF switch to ON to switch on the baby unit and to establish connection with the parent unit.
Why doesn't my parent unit charge while connected to AC power?	Make sure the power is not controlled by electronically controlled wall switch. The battery may be degraded through extended use or defective. See Warranty for repair/replacement.
Why is my screen in black and white?	The screen is in black and white during night-time or in a dark room when the night vision feature is activated. This is normal.
Why do I get glare or blurry display on my screen when viewing my baby at night?	During night-time or in a dark room, the surroundings and other interfering factors, like lighting, objects, colours and backgrounds may affect the image quality on your parent unit screen. Adjust the baby unit angle or place the baby unit at a higher level to prevent glare and a blurry display.
Why does the baby monitor produce a feedback noise?	The parent unit and baby unit may be too close to each other. • Move the parent unit away from the baby unit until the noise stops; OR • Turn down the volume of your parent unit.
Why does the parent unit beep?	The baby unit may be out of range. Move the parent unit closer to the baby unit (but not less than 1 metre). The parent unit may not have enough charge for the parent unit to perform normally. Charge the battery in the parent unit until the battery icon becomes solid  . The temperature of your baby's room may be too high or too low.
Why does the parent unit react too quickly to other sounds?	The baby unit also picks up other sounds than those of your baby. Adjust the VOX sensitivity level to a lower level or lower the parent unit speaker volume.
Why don't I hear a sound/Why can't I hear my baby cry?	The parent unit speaker volume may be too low. See Adjust parent unit speaker volume to increase the volume.
Why can't I establish a connection? Why is the connection lost every now and then? Why are there sound interruptions?	The baby unit may be out of range. Move the parent unit closer to the baby unit (but not less than 1 metre). Other electronic products and wireless products may cause interference with your baby monitor. Try installing your baby monitor as far away from these devices as possible.

🧤 GENERAL PRODUCT CARE

To keep this product working well and looking good, follow these guidelines:

- Avoid placing it near heating appliances and devices that generate electrical noise (for example, motors or fluorescent lamps).
- DO NOT expose it to direct sunlight or moisture.
- Avoid dropping the product or treating it roughly.
- Clean with a damp cloth.
- DO NOT immerse the parent unit and the baby unit in water and do not clean under running water.
- DO NOT use cleaning spray or liquid cleaners.
- Make sure the parent unit and the baby unit are dry before you connect them to the mains again.

📦 STORAGE

When you are not going to use the video monitor for some time, store the parent unit, the baby unit and the adaptors in cool, dry location.

👤 ADULT SUPERVISION

- This baby monitor should be for use by adults only.
- Do not place the baby unit inside the cot or playpen.
- To ensure your children's safety, do not allow them to touch or play with the baby monitor and its accessories. THIS IS NOT A TOY.

🛒 CUSTOMER SERVICE AND PRODUCT WARRANTY

ONE YEAR PRODUCT WARRANTY

Thank you for choosing this quality product from VTech.

- The product detailed above is covered by a one year warranty from the date of purchase, against any defects in materials or workmanship.
- The product may be returned to the place of purchase. Alternatively the product can be returned to VTech Electronics Europe Plc (see address below), with proof of purchase, without proof of purchase no replacement will be provided.
- VTech Electronics Europe Plc will examine the product and if it is found to be defective due to faulty materials or workmanship, will replace the product at their discretion.
- If the product covered by this warranty is damaged due to misuse, modification or unauthorized repair, or because of faulty batteries, battery discharge or incorrect electrical connections, then this warranty becomes void.
- This warranty is personal to the original purchaser and is not transferable.
- Breakages to the LCD screen are not covered by the warranty.
- Products returned to VTech Electronics Europe Plc, should be sent to the address shown below and packed carefully to avoid damage in transit. Please do not include batteries or adaptors. Please include details of the fault together with your name and address, contact phone number and/or email address.
- To keep an online record of your warranty, please register your product online at www.vtech.co.uk/clubvtech.

VTech Electronics Europe Plc, c/o XPO Logistics, Warehouse 350, Cat & Fiddle Lane, West Hallam, DE7 6HE

THIS WARRANTY IS OFFERED AS AN EXTRA BENEFIT AND DOES NOT AFFECT CONSUMERS' STATUTORY RIGHTS.

This warranty is valid for the UK and Ireland only. For products purchased outside the UK and Ireland, please contact your local distributor or place of purchase.

IMPORTANT

Please retain this booklet with your sales receipt as proof of the date of purchase.

Customer Service

Please visit www.vtechphones.eu to contact our Customer Service Department.

♻️ DISPOSAL OF BATTERIES AND PRODUCT



The crossed-out wheeled bin symbols on products and batteries, or on their respective packaging, indicates they must not be disposed of in domestic waste as they contain substances that can be damaging to the environment and human health.



The chemical symbols Hg, Cd or Pb, where marked, indicate that the battery contains more than the specified value of mercury (Hg), cadmium (Cd) or lead (Pb) set out in Battery Directive (2006/66/EC).

The solid bar indicates that the product was placed on the market after 13th August, 2005.

Help protect the environment by disposing of your product or batteries responsibly.

📄 DECLARATION OF CONFORMITY

This product is intended for use within Europe and UK.
This equipment complies with the essential requirements to EU's Radio Equipment Directive (2014/53/EU) and the UK's Radio Regulations 2017 on radio systems and telecommunication equipment.

VTech Telecommunications Ltd. hereby declares that this Video Monitor VM819 is in compliance with the essential requirements and other relevant provisions of EU's Radio Equipment Directive (2014/53/EU) and UK's Radio Equipment Regulations 2017.
The Declaration of Conformity for the VM819 is available from www.vtechphones.eu.



Manufacturer: VTech Telecommunications Ltd.
23/F., Tai Ping Industrial Centre, Block 1, 57 Ting kok Road, Tai Po, Hong Kong.

Importer: VTech Electronics Europe Plc
Napier Court, Abingdon Science Park, Abingdon, Oxon, OX14 3YT, U.K.